

# The Social Atom Diagram Expanded

by Dr Neil E. Hucker

Neil Hucker has a private practice as a psychiatrist in Melbourne. He has a special interest in the application of the psychodrama method to psychiatric disorders and in particular its use in one-to-one psychotherapy.

In this article he presents an expanded three-dimensional representation of the social atom diagram. Neil describes how this representation captures a dynamic flowing process. He illustrates its usefulness in work with a client.

One of the unique elements of psychodramatic work is that it allows the visualisation of a person's experience in three-dimensional space on the stage. As scenes emerge progressively in a psychodrama, different social atoms or aspects of social atoms are displayed. To help me record and explore this complexity in my mind, I have been developing the visual representation shown below. It integrates a record of the social atom, the cultural atom and the person's sociometry.

By creating this three-dimensional representation of a person's collective social atom, I can interact more creatively and comprehensively in my imagination. It allows me to fly or swim around the diagram and interact with the sociometric process in a much more wholistic way.

The representation is in the form of a tree which allows me to warm up to the dynamic recycling flow of life.

### The Expanded Diagram

The diagram schematically represents an individual's self (a,b,c) at a particular point in time in their life. There is a core base (a) and an ascending trunk (b) which is surrounded by the current social atom being dealt with (d). The stack of social atom records (e) represents the accumulated social atom experiences of this person. I imagine this as a stack of 45 records or CDs (depending on one's vintage) which can be played as required and the one which is being focused on becomes (d).

From the overhanging extensions (c) descending branches (f), representing the

patient's roles or role clusters intersect at (g) representing the relevant people on the standard social atom diagram.

The basic core of the individual's self structure (a,b,c) is constructed of three concentric layers representing the central psychosomatic roles (h), the psychodramatic roles (i) and the social roles (j). These layers extend down through (f) and are expressed in the relationships in the social atom.

Each person (g) in the protagonist's social atom (d) has their own social atoms (k) in which they are at the centre (g). Within (k) I can display my protagonist's position (l) in relation to this person.

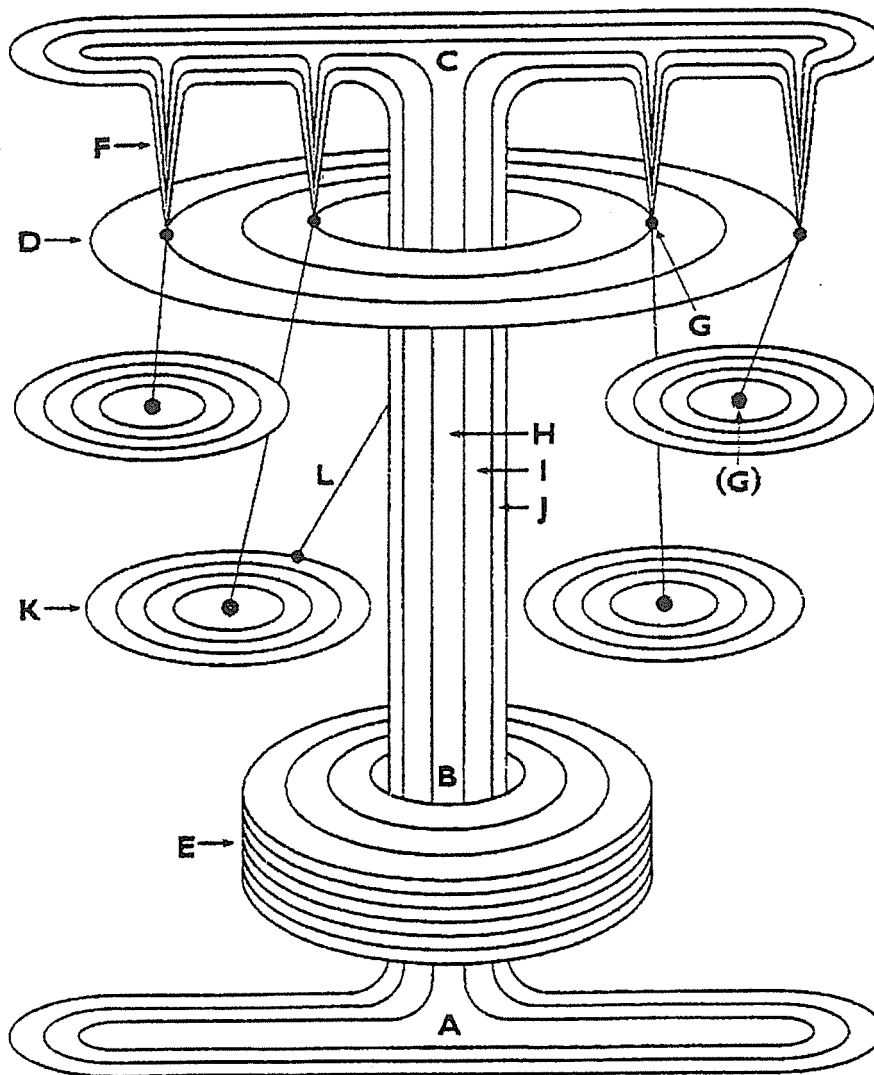

FIGURE 1: THE EXPANDED DIAGRAM

### Using the Expanded Diagram

I use this diagram in recording and reflecting on my work with patients. When I see a person's social atom constellations in this way, a schematic dynamic flow very much like cartoon images emerges. This complements my imagining of the actual people in the person's world.

The core (a,b,c) can be seen as an ongoing flowing state of a person as they function from moment to moment. Made up of all that has gone before within the recorded social atoms (e) as well as what is going on in the present (d).

From this core, interactions with specific people (g) warm the protagonist up to a range of roles (f) that emerge in their social atom. These roles or clusters can manifest themselves singly or as a cluster of psychosomatic, psychodramatic and social roles (h,i,j).

In psychodrama explorations, a person's roles (f) in their own social atoms (d) at different times (e) are enacted. These roles are enacted in the other people's social atoms (k). Often sequences of scenes are displayed tracing back to the spontaneity state that created the conserved role. The stack of records (e) gives me a very easy visual representation of the person's roles and their social atom history.

### Case Example

I used this expanded social atom representation in the following clinical situation:

A person (a,b,c) presents to me (G) in the role of the suicidally depressed grieving sibling (f), following the unexpected death of a sibling ((G)) in an accident. At the time of presenting, the patient's relationship with his brother has been the most significant positive relationship in his social atom. In the brother's social atom (l) the patient was not the only person the brother has a positive link with. In all of the social atoms of his siblings and particularly in the social atoms of his mother and father, the patient experiences himself as an estranged outsider.

When I explored his past social atom configurations (e) using the criteria of significant loss and abandonment, the following events were displayed. I will list them chronologically to show how they appear to me as a stack of social atom records.

1. Loss of brother.
2. Loss of most recent girlfriend.
3. Loss of a significant career position.
4. Loss of other girlfriends.
5. Abandonment by mother after parental separation.
6. Loss of family unit and parental marital unit.
7. Loss of another sibling at the age of eight.
8. Loss of a sense of having any value in his father's eyes as a young child.
9. Loss of first child exclusiveness with the birth of subsequent siblings.

At the time of each of these events there is a specific social atom configuration within which loss and grief occurred. When each of these situations emerges spontaneously or are explored systematically, an ongoing series of unresolved grieving processes are exposed. The repetitive role displayed is the withdrawn, isolating, unexpressing and grieving child. As the various phases of the current grief over the dead brother are worked through, each of the preceding unresolved grief situations emerge. This allows a more complete degree of social atom repair to occur.

Eventually, the helpless, hopeless lover's core belief emerges. 'Whoever I love and enjoy leaves me because there is something wrong with me. It is all my fault.' Once the inadequacy of this belief is confronted and resolved, the person is able to again rework the various loss situations and complete the social atom repair and healing.

During our work together a change evolved in people's positions in my patient's current social atom (d). His position in their social atoms (k) moved from isolate to an ongoing enjoyer of family life and relationships.

### Conclusion

This visual representation of the current social atom (d), and the collection of previous significant social atom configurations (e), allows me as a social atom systems analyst to have a flexible structure to remember, explore and experience a person's social atom movements with.

When the people in a particular person's social atom are displayed like this, the fractal extensions of social relatedness in the here-and-now and in the past can be displayed ad infinitum.

When I visualise and represent the social atom system and its history in this three dimensional schematic way, I am able, by floating through it interactively, to hold the complexity of a person's relationships more comprehensively. It also helps me to not underestimate the sociometric links involved in the life of a person's social atom.

*the fractal extensions of  
social relatedness in  
the here-and-now and  
in the past can be  
displayed ad infinitum*